



Max Lifting
Height 5.5m

Working Radius 5.17m

Capacity
1.72t x 1.0m

Weight
1290kg

MC174



The Maeda MC174 sets the standard that other mini cranes try to achieve. Its super slim width of 590mm coupled with its 1.72 ton lifting capacity make it absolutely unparalleled. This fantastic machine also retains all of the other benefits of the machines in the Maeda range including a 2 year warranty, remote control and unrivalled build quality and usability.

- 1.72 Ton Max capacity
- 5.5m Max Working Height
- Super Slim Body Width (590mm)
- Low Ground Pressure
- Manoeuvrability & Stability
- Programmable Moment Limiter
- Tilt Alarm
- High Speed Winch
- 2 Travel Speeds
- Remote Control
- Optional 300kg Searcher Hook
- 2 Year Warranty

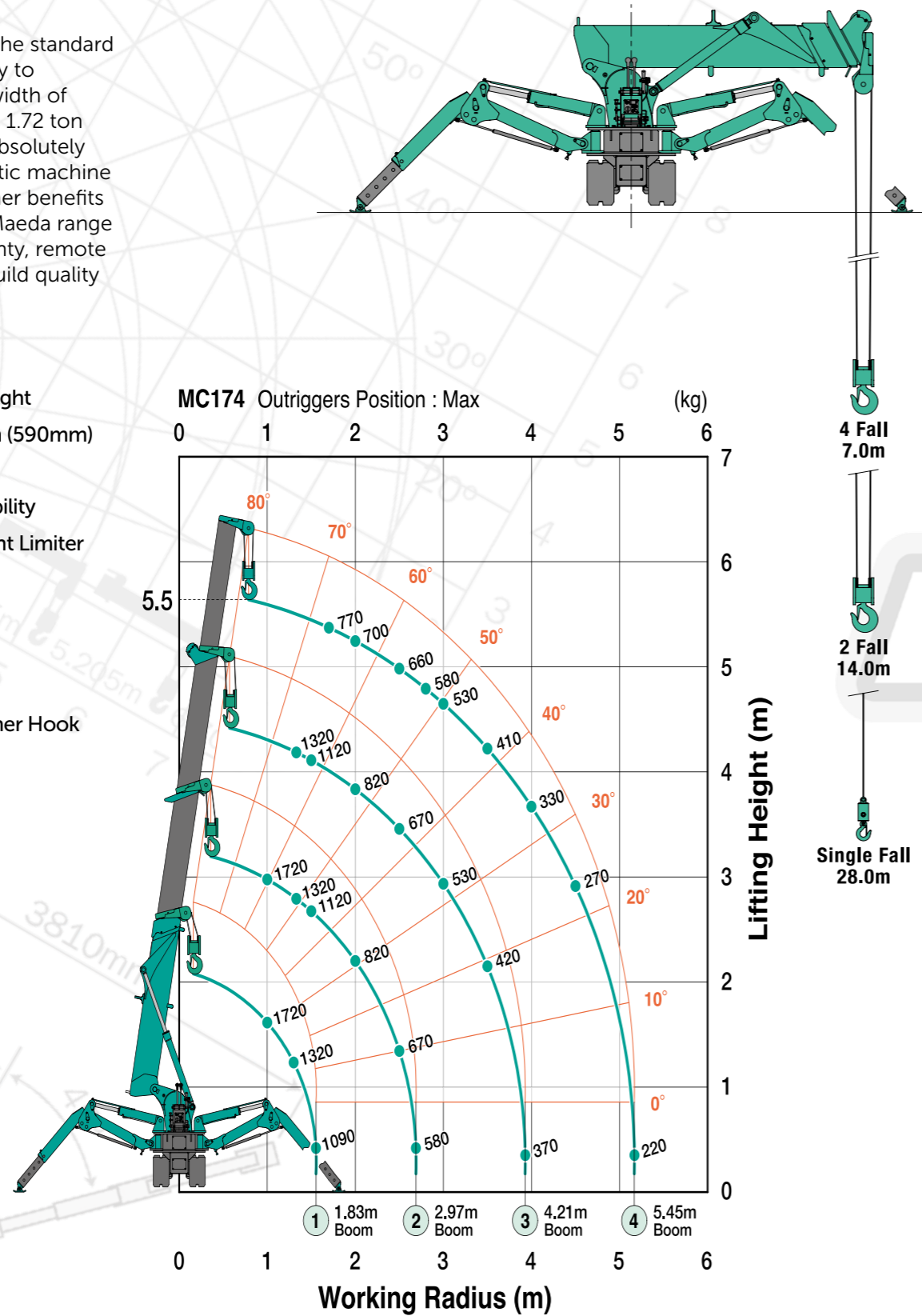

This working range chart shows total rated load including boom deflection.

Total rated load with Outriggers at Maximum position with 300kg Searcher Hook

1.83m boom		2.97m boom		4.21m boom		5.45m boom	
Working radius (m)	Total rated load (kg)	Working radius (m)	Total rated load (kg)	Working radius (m)	Total rated load (kg)	Working radius (m)	Total rated load (kg)
<1.0	300	<1.0	300	<1.30	300	<1.70	300
1.30	300	1.30	300	1.50	300	2.00	300
1.55	300	1.50	300	2.00	300	2.50	300
		2.00	300	2.50	300	2.80	300
		2.50	300	3.00	300	3.00	300
		2.69	300	3.50	300	3.50	300
				3.93	300	4.00	250
						4.50	200
						5.17	150

Total rated load Outriggers at Maximum position

1.83m boom		2.97m boom		4.21m boom		5.45m boom	
Working radius (m)	Total rated load (kg)	Working radius (m)	Total rated load (kg)	Working radius (m)	Total rated load (kg)	Working radius (m)	Total rated load (kg)
<1.0	1720	<1.0	1720	<1.3	1320	<1.7 or	770
1.30	1320	1.30	1320	1.50	1120	2.00	700
1.55	1090	1.50	1120	2.00	820	2.50	660
		2.00	820	2.50	670	2.80	580
		2.50	670	3.00	530	3.00	530
		2.69	580	3.50	420	3.50	410
				3.93	370	4.00	330
						4.50	270
						5.17	220

Total rated load Outriggers at any other position

1.83m boom		2.97m boom		4.21m boom		5.45m boom	
Working radius (m)	Total rated load (kg)	Working radius (m)	Total rated load (kg)	Working radius (m)	Total rated load (kg)	Working radius (m)	Total rated load (kg)
<1.0	1220	<1.0	1220	<1.3	940	<1.7	720
1.30	940	1.30	940	1.50	810	2.00	600
1.55	790	1.50	810	2.00	600	2.50	390
		2.00	600	2.50	390	2.80	330
		2.50	390	3.00	300	3.00	300
		2.69	310	3.50	220	3.50	220
				3.93	180	4.00	180
						4.50	140
						5.17	100

Outrigger Footprints

Diagram shows outriggers at maximum position.

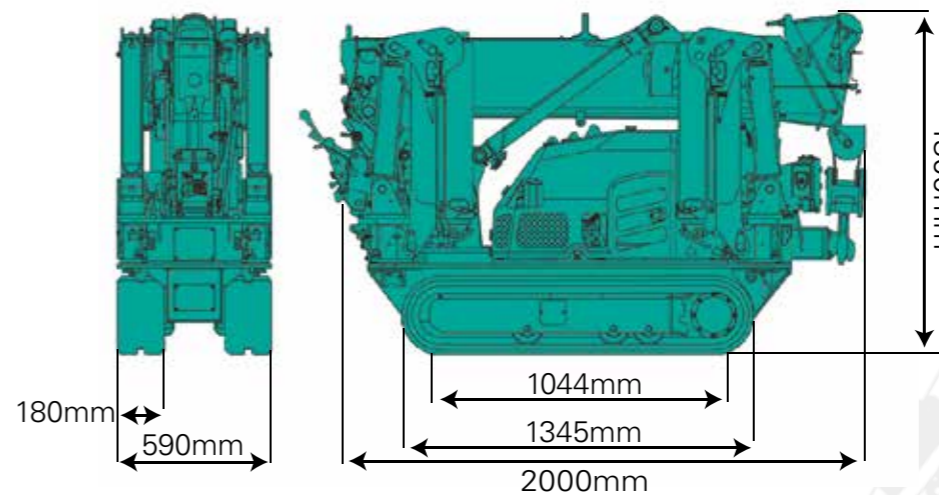
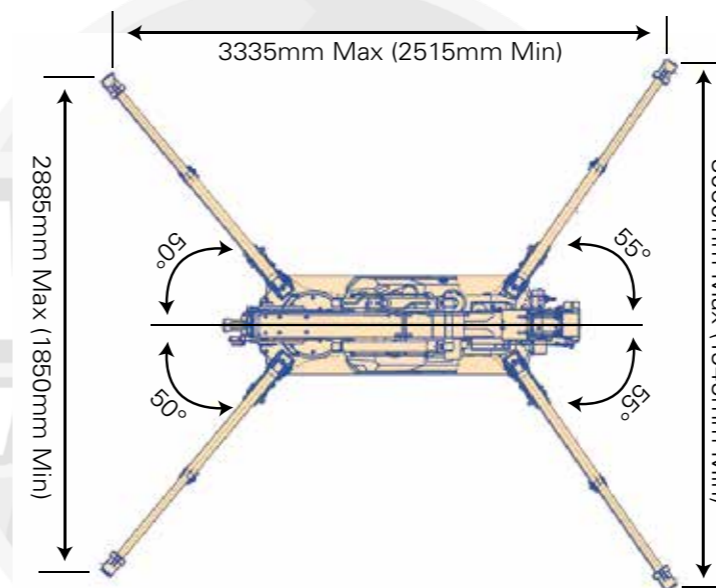

- When using two fall or single fall hooks, use the appropriate four fall Total Rated Load Chart but with a maximum load of: Two Fall - 860kg, Single Fall - 430kg.



MC174

Specifications

Capacity	Maximum	1.72t x 1m
Working radius	Maximum	5.17m x 220kg
Lifting height	Maximum	5.5m x 770kg
Dimensions	MC174	2000mm x 590mm x 1300mm
Weight	MC174 Hook block weight	1290kg 20kg
Hook speed	Maximum	10.9m / min. (4 falls, 3rd layer)
Single line speed	Maximum	43.6m / min. (3rd layer)
Hoist rope	Type	IWRC 6 x Fi (29) Ø 6mm x 35m
Telescopic system	Boom length Telescoping speed Boom type	1.83m - 5.45m 3.62m / 15 sec. Fully automatic 4 section pentagonal telescopic boom
Boom hoist system	Hoist angle / speed	3° - 77° / 12 sec.
Slew system	Slew angle / speed	360° continuous / 2.0 rpm
Outrigger system	Type Maximum outriggers	4 Multi position box type. Hydraulic cylinders with lock valves (Length) 3335mm x (Front) 3060mm x (Rear) 2885mm
Traction system	Drive Travel speed Gradability Ground length x width Ground pressure	Hydrostatic type, stepless forward and reverse 0 - 3.3km/h 20° 1044mm x 180mm (Track dimensions) 0.34 kgf / cm ²
Engine	Model Type Rated output Starting method Fuel tank capacity	Mitsubishi GB400LE 1 Cylinder, Air Cooled, Petrol 6.6kW / 1800 rpm Electric Petrol / 6L
Safe load indicator	Made specifically for Maeda Mini Cranes with a fully programmable working envelope	
Standard equipment	Cable remote control, overwind protection, hydraulic safety valves, working light, hour-meter, 4-fall hook block, black rubber tracks, moment limiter, EMO switch, level, tilt alarm, working status lamp	
Optional equipment	White rubber tracks Single fall hook Two fall hook 300kg searcher hook Radio remote control LPG kit Electric 380/400V power pack	

